

## BEAVER PRODUCTS

### Beaver Roval Truck Wheel Wrenches

Code	Description	Weight Each (Kg)	UOM
TWB032	32mm x 17mm x 300mm	2.375	Each
TWB035	35mm x 17mm x 300mm	2.375	Each
TWB038	38mm x 21mm x 395mm	3.667	Each
TWB041	41mm x 21mm x 395mm	4.000	Each
TWB041A	41mm x 19mm x 395mm	3.833	Each
TWB114A	11/4" x 11/16" x 395mm	3.500	Each
TWB118	11/8" x 15/16" x 395mm	3.500	Each
TWB516	15/16" x 21mm x 395mm	3.500	Each
TWB516A	15/16" x 11/4" x 395mm	3.500	Each
BARTWW040	400mm Wrench Bar Only	0.920	Each
BARTWW050	500mm Wrench Bar Only	1.917	Each



## BEAVER JACK SERIES

### Beaver Roval Black Jax Series Bottle Jacks

Complies to AS/NZS 2693

Code	Description	Capacity Tonnes	D mm	D2 mm	H2 mm	W mm	Screw Adjusting Height mm	Lift Height mm	Minimum Height H minimum mm	Maximum Height H maximum (Kg)	Weight (Kg)	UOM
Jax00186	Bottle Jack	1.86	60	30	76	109	60	125	200	385	3.8	Each
Jax004	Bottle Jack	4	70	32	79	109	80	125	200	405	4.8	Each
Jax006	Bottle Jack	6	70	29	81	109	70	127	216	413	4.6	Each
Jax008	Bottle Jack	8	85	40	83	135	80	160	240	480	7.3	Each
Jax010	Bottle Jack	10	95	43	84	148	80	160	245	485	9.3	Each
Jax015	Bottle Jack	15	102	45	85	158	85	170	245	500	12.6	Each
Jax020	Bottle Jack	20	114	54	86	165	90	192	278	560	16.4	Each

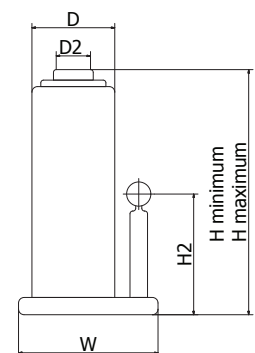

## BEAVER JACK SERIES

### Beaver Roval Squat -Jax Series Bottle Jacks

Complies to AS/NZS 2693 – Designed for use where 12 – 20 tonne lift is required, but ground clearance does not exceed 195mm

Code	Description	Capacity Tonnes	D mm	D2 mm	H2 mm	W mm	Screw Adjusting Height mm	Lift Height mm	Minimum Height H minimum mm	Maximum Height H maximum (Kg)	Weight (Kg)	UOM
BJS012	Squat Bottle Jack	12	95	43	84	136	65	105	191	361	7.6	Each
BJS016	Squat Bottle Jack	16	110	45	85	150	65	110	191	356	9.4	Each
BJS020	Squat Bottle Jack	20	114	45	92	166	72	113	191	376	11.3	Each

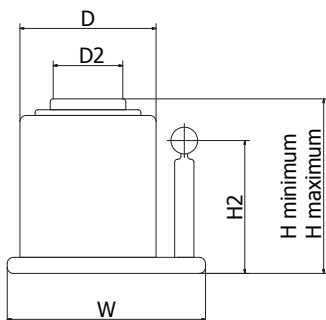

### Beaver Roval Trolley Jack

Complies to AS/NZS 2615 D.I.Y. Home Mechanic

Code	Description	Capacity Tonnes	D mm	H2 mm	W mm	Wheelbase Length mm	Minimum Height H minimum mm	Maximum Height H maximum mm	Nett Weight (Kg)	UOM
TJK014	Trolley Jack	1.4	50	132	492	410	130	350	11	Each

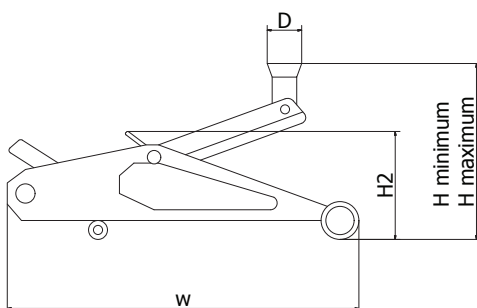

## Beaver Roval Trolley Jack Garage

*Complies to AS/NZS 2615 With quick lift pedal*

Code	Description	Capacity Tonnes	D mm	H2 mm	W mm	Wheelbase Length mm	Minimum Height H minimum mm	Maximum Height H maximum mm	Nett Weight (Kg)	UOM
GJK022	Trolley Jack w/- quick lift pedal	2.25	120	155	685	520	145	490	39.5	Each

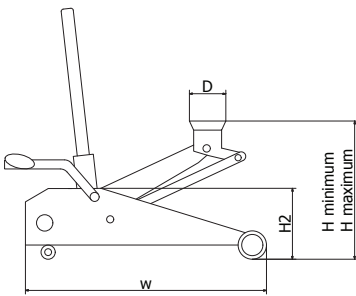

## BEAVER JACK SERIES (CONT'D)

### Beaver Roval Air / Hydraulic Trolley Jack

Code		Description	Capacity Tonnes	D mm	H2 mm	W mm	Minimum Height H minimum mm	Maximum Height H maximum mm	Nett Weight (Kg)	UOM
GJK200	TQ22001	Air/Hydraulic Trolley Jack	20	280	360	660	265	510	46	Each

